

WOODStore.net

Browse more than 1000 plans, projects, books, techniques, & more

Thank You!

Thank you for ordering a WOOD® magazine download. We hope you enjoy being part of our online experience and that you have fun expanding your woodworking skills.

Please remember that this copyrighted material is for your use only. It is unlawful to share this file with someone else or to reprint it in any form.

Bill Krier
Editor in Chief, WOOD magazine

Adobe Acrobat Reader Troubleshooting Guide

If you can read this page, your Acrobat Reader program is working correctly! But you may still have problems or specific issues, such as printing and saving your downloadable file.

My printer won't print the text correctly
Almost all printing problems are due to not enough free system resources memory. The files are very memory intensive because they include graphics, text, and photos. Close all other programs/applications and print directly out of the Acrobat Reader program, not your Web browser.

Patterns are not printing full-size
Make sure your printer is set to print at 100 percent and that "print to fit" is not checked. These settings are selected in the printer setup or printer options.

I can't save my file now that it's downloaded
You must save the plan when you download the file. Download the file again, except this time try right-clicking on the red download button. A menu window will open. Select "Save target as" or "Save link as" to save the file to your hard drive. Once saved, you can open it up with Adobe Acrobat Reader.

For more details on using Adobe Acrobat Reader please visit our online help section at:
<http://www.woodstore.net/clicherforde.html>

WOOD Store Customer Favorites

Shop Tools & Accessories



Indoor Furniture



Outdoor Furniture

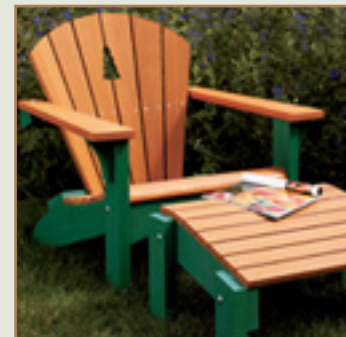

Mission Furniture

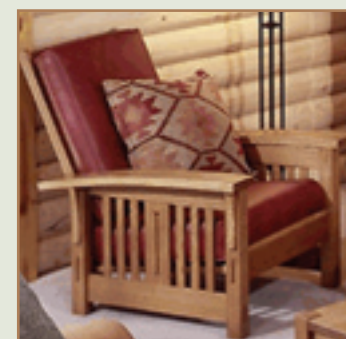

Visit the WOOD Store at:
WOODStore.net



spice up your next meal
with this dashing duo

Salt & Pepper Shakers



This contemporary condiment set seems to display ebony side accents. But, look again! Those black stripes are really ordinary O-rings, and they hold the lids on these cleverly designed salt and pepper shakers.

EXPLODED VIEW

1" hole drilled 1/2" deep into bottom of lid

3/32" holes

3/4"-thick lid

O-ring

1" hole 3" deep

O-ring

3/8 x 3/8 x 4 1/8" legs
glued into rabbets

Bottom of leg
and bottom of shaker
are flush

Start with $1\frac{5}{8} \times 1\frac{5}{8} \times 18$ " stock for the shakers. (We used oak.) You'll also need two pieces of stock $\frac{3}{8} \times \frac{3}{8} \times 18$ " (one light wood and one dark to identify the salt and pepper shakers—we used ash and walnut). The 18" stock will yield two shaker sets. We chose that length for safety and convenience when machining parts.

On the $1\frac{5}{8}$ "-square stock, cut the $\frac{5}{16}$ " rabbets shown on the Shaker Stock drawing. A table-mounted router with a $\frac{3}{8}$ or $\frac{1}{2}$ " straight bit does the job easily. Just set the router-table fence for the $\frac{5}{16}$ " rabbet width. Rabbet two corners diagonally opposite each other, cutting to $\frac{5}{16}$ " deep. To avoid splintering, don't attempt to reach final depth in one pass—make two or three shallow cuts.

Then, change to a $\frac{3}{8}$ " round-over router bit. Rout the remaining two corners of your workpiece.

Crosscut four $4\frac{1}{8}$ "-long sections for the shakers. Saw a $\frac{3}{4}$ " length from the top of each section; this will be the lid. The remaining portion will be the shaker body. So that you can match the grain

when you assemble the shakers, mark each lid and body pair as you cut them apart. Draw diagonal lines to find the center on top of each body and on both the top and bottom of each lid.

Now, cut the foot on the bottom of each shaker body. To do this, first attach an extension to your miter gauge. Clamp a stopblock to the extension, setting the distance to the blade at $3\frac{1}{8}$ ", or $\frac{1}{8}$ " less than the overall length of the shaker body. (See the Sawing the Foot drawing.)

Adjust the tablesaw cutting depth to $\frac{3}{16}$ ". With the top of the shaker body against the stopblock, saw each side in turn. Then, rotate the workpiece, placing one rounded corner against the saw table and a rabbeted corner against the miter-gauge extension. Clamp in position, and cut. Repeat for the other corner.

Raise the saw blade to $\frac{3}{2}$ " cutting depth. Position the shaker body with a rabbeted corner against the saw table. Make sure both points of the rabbet rest on the surface. Clamp the body to the miter-gauge extension, and cut. Repeat for the other corner.

Chuck a 1" Forstner bit into your drill press. Lower the point of the bit to $\frac{1}{4}$ " above the drill press table, and set the depth stop. Center the bit over the top of the body, and clamp the body securely to the drill-press table or fence. (We gripped the body with a handscrew clamp, then clamped the handscrew to the table with another.)

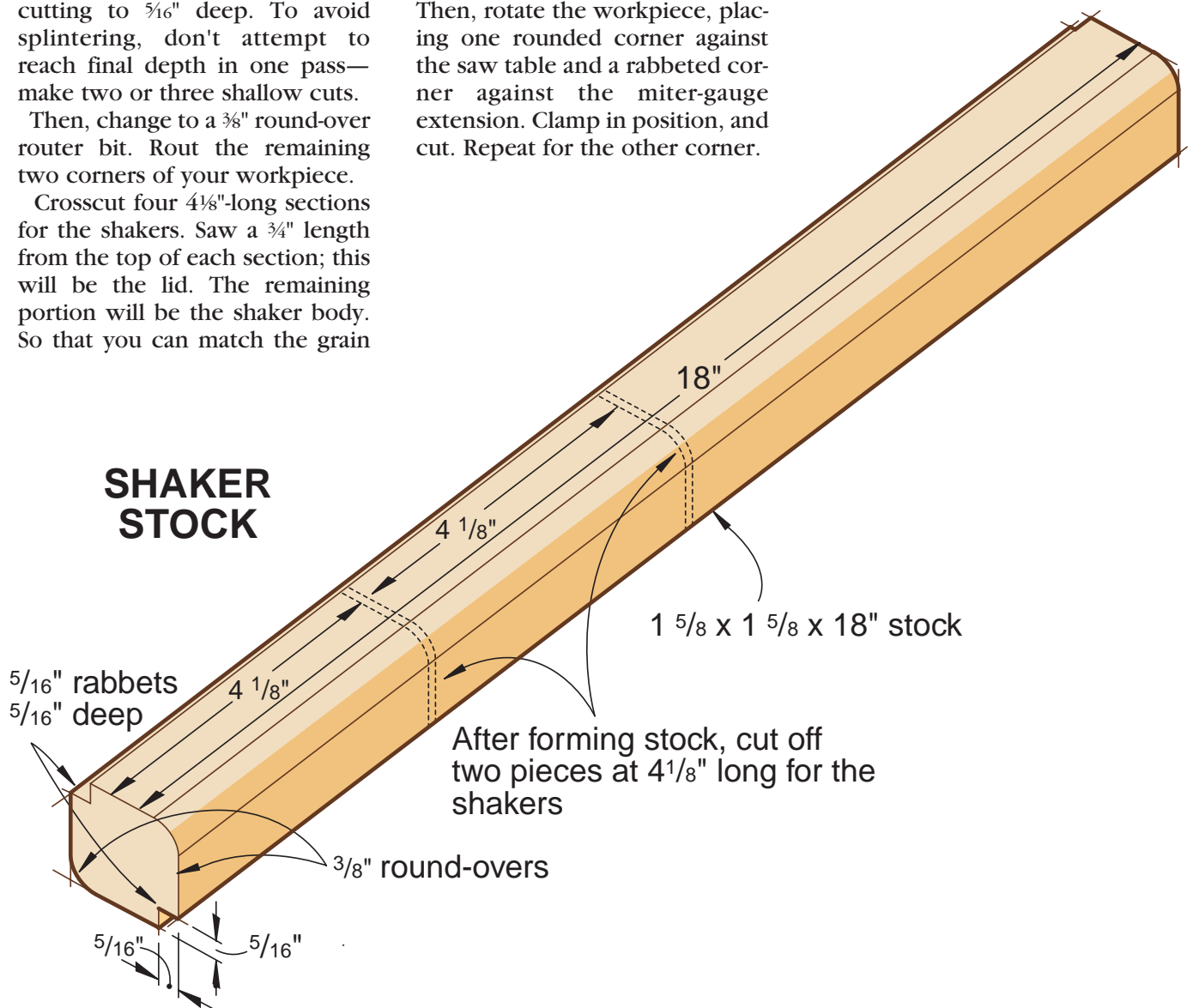

Bore the hole, withdrawing the bit several times to clear chips. Without changing the depth stop, clamp and bore the bottom of the lid. Change to a $\frac{3}{32}$ " brad-point bit to drill the five holes in the lid. To locate the holes, draw a $\frac{5}{8}$ "-diameter circle around the center marked on top of the lid. Drill one hole at the center, the other four where the circle intersects the diagonal lines.

Cut the $\frac{3}{8}$ "-square stock to $4\frac{1}{8}$ " lengths for the legs. Make walnut legs for the pepper shaker, ash ones for the salt shaker.

Sand all parts. Slightly round all edges and corners, except the outside corners of the rabbets.

To assemble, apply woodworker's glue to the rabbeted corners of the body. Stand the body on a flat surface, and locate the legs in the rabbets. Set them flush with the bottom, and clamp with rubber bands.

After the glue dries, remove any squeeze-out with a sharp chisel or X-Acto knife. Finish the outsides with salad bowl oil or polyurethane. Slide the lid into place on each shaker, and secure it by looping a $1\frac{1}{8}$ " or $1\frac{3}{4}$ " O-ring, $\frac{1}{16}$ " diameter, over each leg at the top and bottom. If the lid doesn't slide into place readily, wax the rabbet or the legs.♣

Produced by Marlen Kemmet
Project design: © Rhett Zoll, Zoll Woodworks
Graphic Design: Jamie Downing
Illustrations: Kim Downing
Photograph: Hetherington Photography
©Copyright Meredith Corporation 2002

The purchase of these plans does not transfer any copyright or other ownership interest in the plans, the design, or the finished project to the buyer. Buyer may neither reproduce the plans for sale nor offer for sale any copies of the finished project.

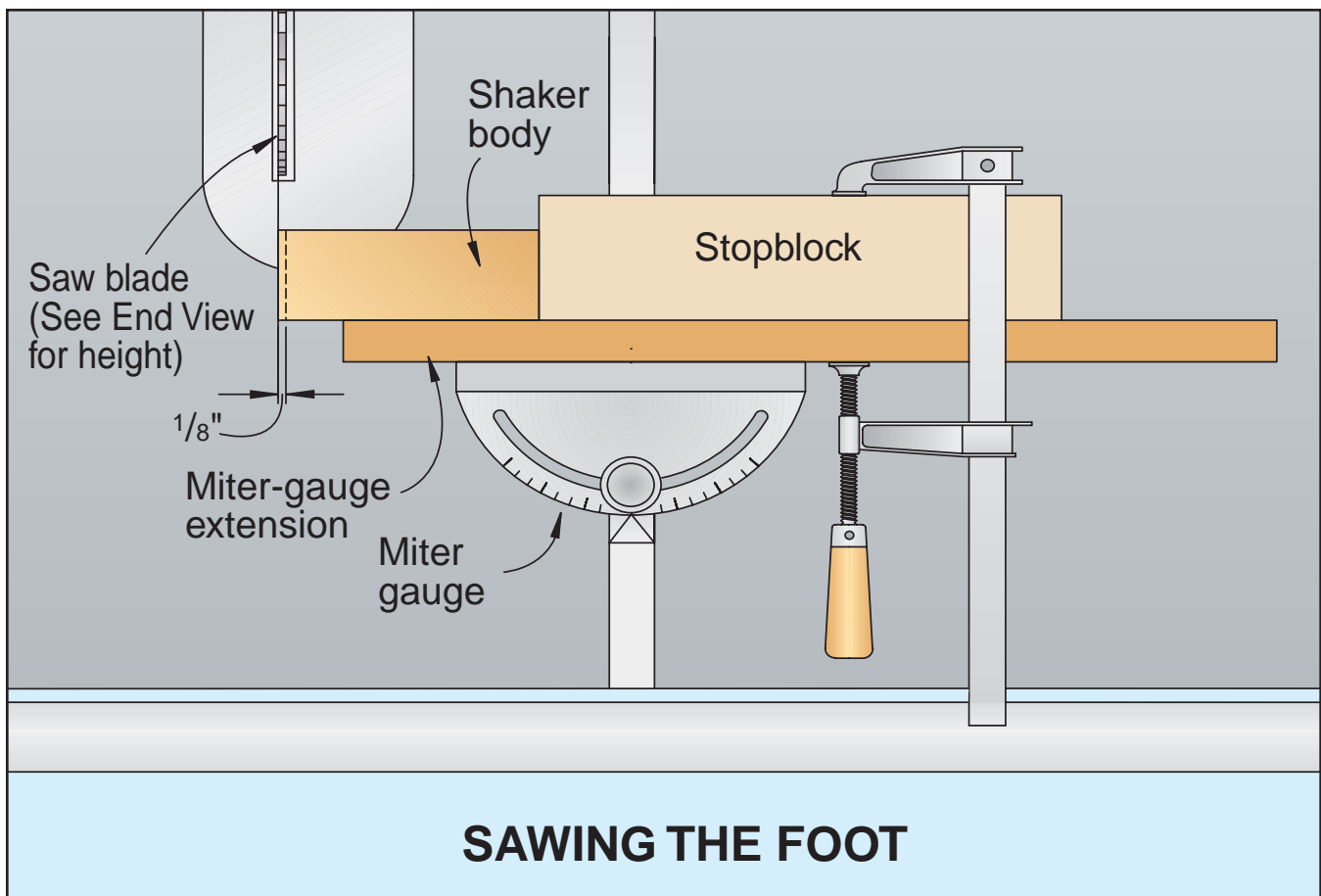

**FULL-SIZED
TOP VIEW**

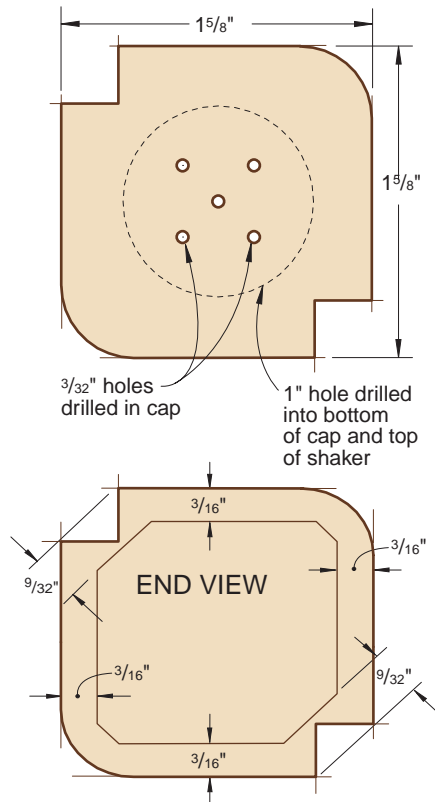

To ensure full-sized patterns are correct size, your printer should be set to print at 100% (not fit to page). Measure full-sized patterns to verify size.

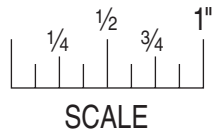

WOODStore.net

Browse more than 1,000 woodworking project plans, articles, tool reviews, books, techniques, & more. Each plan includes step-by-step instructions, professional color photography, and detailed illustrations.



Plans

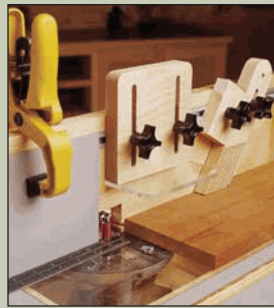

Techniques

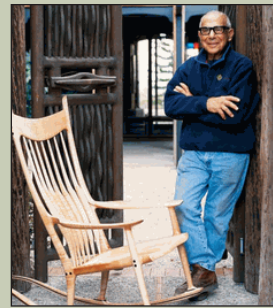

Articles



Publications

WOODWorkersCenter.com

Looking for information from leading woodworking companies?

WOODWorkersCenter.com is just the site for your woodworking tool, accessory, and service informational needs. Use the online info request feature to request these companies latest catalogs or info.



WOODmagazine.com

The online presence of WOOD magazine, WOODmagazine.com speaks to online users of all woodworking skill levels with free woodworking plans, helpful forums, numerous articles, and numerous services to help you become a better woodworker. Visited by over 200,000 woodworkers per month, this site is geared to provide you with helpful information and shop-tested advice.

